

## Fast – smart – perfect: 1394b goes Pike.



### Description

The AVT Pike camera family is equipped with an IEEE 1394b (S800) interface, as well as high-quality CCD sensors and comes in a surprising variety of different versions for the most demanding applications. The Pike offers a selection of six different high-quality sensors (b/w and color) with high sensitivity and true-to-life color reproduction. To meet the highest requirements in the industry, the Pike comes optionally in a version with a copper daisy chain connection or 1 x copper combined with 1 x GOF connector (2 x optical fiber on LCLC). This not only saves costs in multi-camera operations but also makes it possible to use up to 500 meters of cable. The direct fiber technology of the Pike in the GOF version also provides for equalization of potential and EMC independence. The high data rates of the Pike (max. 62.5 MByte/s) and a huge number of smart features ensure an extraordinary performance in PC-based image processing.

The integrated image pre-processing of the Pike not only reduces demands on PC computer power, but also cuts system costs by eliminating the now unnecessary frame grabbers.

### Highlights

- IEEE 1394b
- 1 megapixel (1000 x 1000)
- Up to 60 fps (full resolution)
- Progressive scan CCD, monochrome and color
- True partial scan (higher frame rates by smaller AOI)
- Flexible AOI, flexible speed (full Format\_7 support)
- Image pre-processing features:
  - Auto controlled gain, exposure, white balance
  - Anti-smear mode
  - Color correction, hue, saturation (color only)
  - Real-time shading correction, prog. LUT
  - 2x/4x/8x binning
  - And lots more ...
- Smart frame grabber features:
  - Image FIFO memory (32 full frames)
  - High SNR mode (up to 16 bit)
  - Single-shot, multi-shot, free-run
- 2 prog. inputs, 4 prog. outputs, on-board RS232
  - Sequence mode
  - SIS (secure image signature)
  - And lots more ...
- Industry proven and robust housing
- C-Mount / CS-Mount
- Angled head and customized housings

## Sensor specification b/w

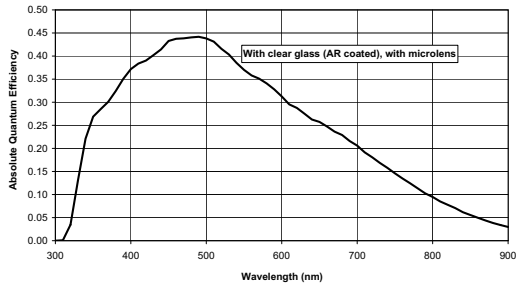

## Sensor specification color

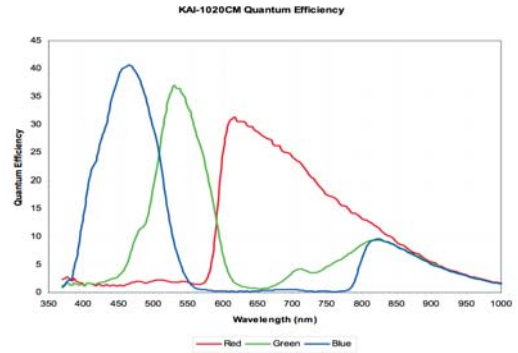

The sensor specifications (excluding lens and filter) are typical for this camera model.

## Dimensions

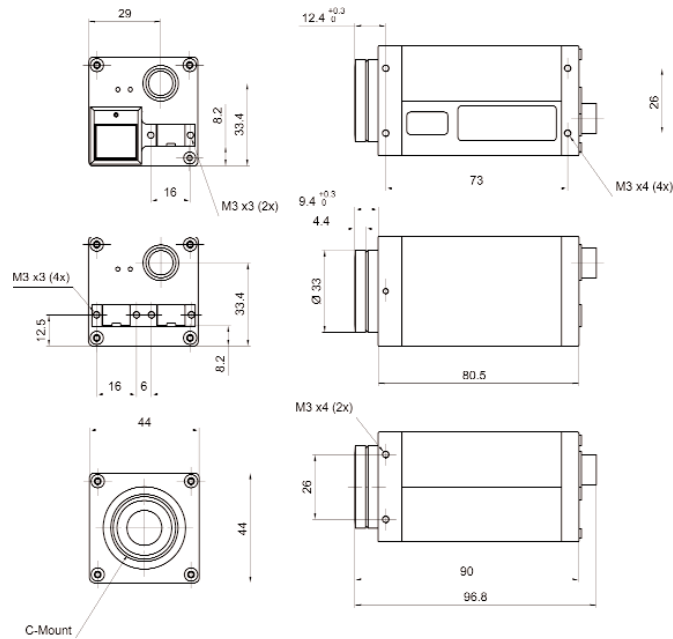

## Connections Copper / Daisy Chain



## Connections Copper / GOF



Preview mode (by sub-sampling)	
AOI height / pixel	Frame rate
1000	60
600	87
480	102
240	149
120	193
60	225
30	251
10	268

I/O Connector	
Pin	Signal
1	External Ground
2	External Power (+8 ... +36 V DC)
3	GP Output 4
4	GP Input 1 (Default: -)
5	GP Output 3 (Default: Busy)
6	GP Output 1 (Default: IntEna)
7	Input GND
8	RxD RS232
9	TxD RS232
10	Output Power (max. 36 V DC)
11	GP Input 2 (Default: -)
12	GP Output 2 (Default: Follow GP Input 2)

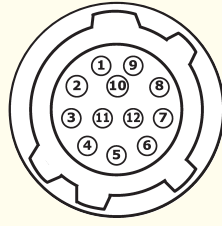

Camera specifications	Pike F-100 B/C	Pike F-100 B/C fiber
Image device	Type 2/3 (diag. 10.5 mm) progressive scan, KODAK IT CCD KAI1020A/C	
Picture size	1000 (H) x 1000 (V) (Format_7 Mode_0)	
Cell size	7.4 μm x 7.4 μm	
Resolution depth	8 bit / 10 bit / 12 bit / 14 bit / 16 bit (High SNR mode)	
Lens mount	C-Mount	
Digital interface	IEEE1394b, 2xbilingual (daisy chain)	IEEE1394b, 1 x bilingual, 1 x GOF connector (2 x optical fiber on LCLC)
Transfer rate	100 Mbit/s, 200 Mbit/s, 400 Mbit/s, 800 Mbit/s	
Frame rates	Up to 60 fps (Mono8, Raw8), 43 fps (YUV 4:1:1), 33 fps (YUV 4:2:2, Raw16), 22 fps (RGB8)	
Gain control	mono: Manual 0-22 dB, auto gain;	color: Manual 0-20 dB, auto gain
Shutter speed	43 μs ... ~ 67 s , auto shutter (select. AOI)	
External trigger shutter	Programmable, trigger level control, single trigger, bulk trigger, programmable trigger delay	
Smart features	AGC/AEC/AWB with autofunction AOI; only color: AWB/color correction/hue/saturation; real-time shading correction, LUT, 64 MB image memory, mirror, binning (only b/w), sub-sampling, High SNR, storable user sets, 2 progr. inputs, 4 progr. outputs, RS-232 port, SIS (secure image signature), sequence mode, anti-smear mode, 4x/8x binning, 12-bit speed increase mode	
Power requirements	DC 8 V bis 36 V (via IEEE 1394 cable or 12-pin HIROSE)	
Power consumption	Typ. 5 watt (@ 12 V DC);	fiber: Typ. 5.75 watt (@ 12 V DC)
Dimensions	96.8 mm x 44 mm x 44 mm (L x W x H); incl. connectors, w/o tripod and lens	
Mass	250 g (without lens)	
Operating temperature	+5 ... +50 ° Celsius housing temperature (without condensation)	
Storage temperature	-10 ... +60 ° Celsius ambient temperature (without condensation)	
Regulations	CE, FCC Class B, RoHS (2002/95/EC)	
Options	IR cut/pass filter (mono), protection glass (color), host adapter card, angled head, power out (HIROSE), AVT FirePackage/Active FirePackage/Fire4Linux	

Design and specifications of the described product(s) are subject to change without notice.  
© 06/2009