

# TG2Z3514FCS-2

**2X 3.5mm - 8mm F1.4**  
**for 1/3 type Cameras, Vari-focal Auto Iris DC Drive**  
**CS-Mount**

with Focus, w/o Amplifier

**1/3**  
type

Model No.	TG2Z3514FCS-2		Effective	Front	Ø16.6mm
Focal Length	3.5mm - 8mm		Lens Aperture	Rear	Ø9.0mm
Max. Aperture Ratio	1:1.4		Back Focal	Tele	13.1mm
Max. Image Format	4.8mm x 3.6mm(Ø6mm)			Length	Wide
Operation Range	Iris	F1.4 - F360C	Flange Back Length		12.5mm
	Focus	0.4m - Inf.	Mount		CS-Mount
	Zoom	3.5mm - 8mm	Filter Size		—
Control	Iris	DC Auto Iris	Dimensions		Ø33.5mm x 42.6mm x 43.5mm
	Focus	Manual	Weight		48g
	Zoom	Manual			
Object Dimension at M.O.D.	3.5mm	64.3cm x 43.9cm			
	8mm	25.5cm x 18.9cm			
Angle of View	D	1/3 type	97.9° - 44.3°	1/4 type	72.7° - 33.2°
	H		77.6° - 35.4°		57.6° - 26.6°
	V		57.6° - 26.6°		43.0° - 19.9°
Coil	Drive	190Ω			
	Control	855Ω			
Operating Temperature	-20°C - +50°C				

M.O.D : Minimum Object Distance

**CS**

## Dimensions

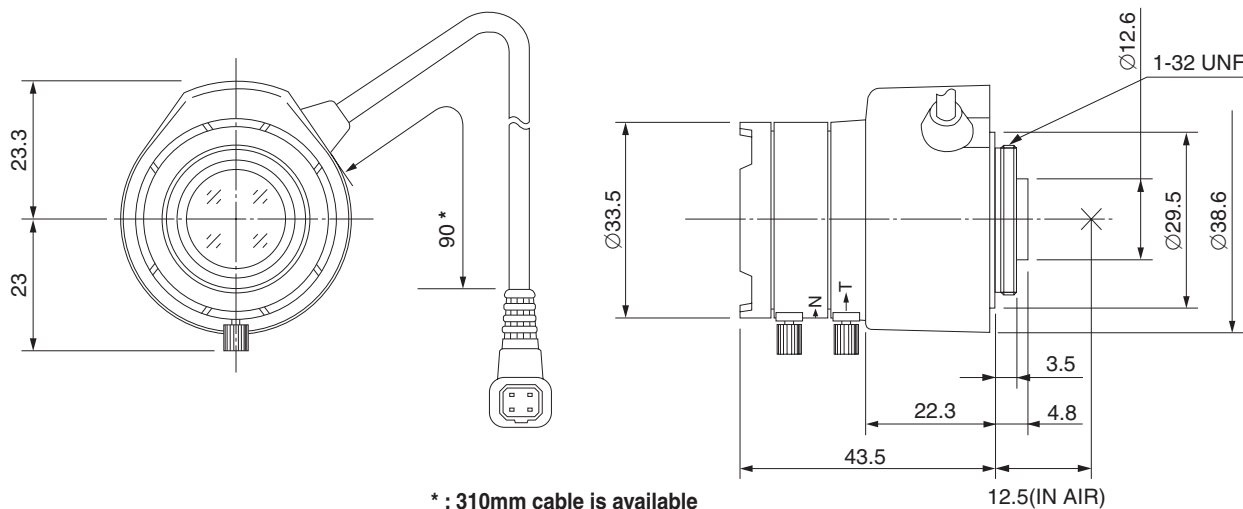

## Wiring Diagram

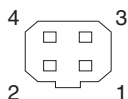

### Pin No.

1	BROWN	Control (-)
2	RED	Control (+)
3	YELLOW	Drive (+)
4	ORANGE	Drive (-)