

HZ10200RDC-II

Image Size: $\frac{1}{2}$ $\frac{1}{3}$ $\frac{1}{4}$

【SPECIFICATIONS】

Focal Length :	10 - 200mm	Flange Back:	17.526mm
Maximum Relative Aperture :	1:1.9	Operation : Zoom :	Motorized(DC8V, Max30mA)
Iris :	F1.9-Approx.360	Focus :	Motorized(DC8V, Max30mA)
Zoom Ratio :	20X	Iris :	IG(Auto Close System)
Angular Field of View :	32.1 × 24.3 deg. at 10mm 1.9 × 1.4 deg. at 200mm	Operation Temperature :	-10 ~ +50
Image Format :	6.4 × 4.8mm(8mm)	Mount :	C-Mount
Minimum Object Distance :	1.5m(From Front Vertex)	Front Thread :	72mm P0.75
Optical Back Focal Distance :	10.21mm(In Air)	Size , Weight :	87 × 80 × 170.5mm, Approx .880g

【COMPOSITION】

Lens1
Lens Cap1
Dust Cap1

【DIMENSIONS】

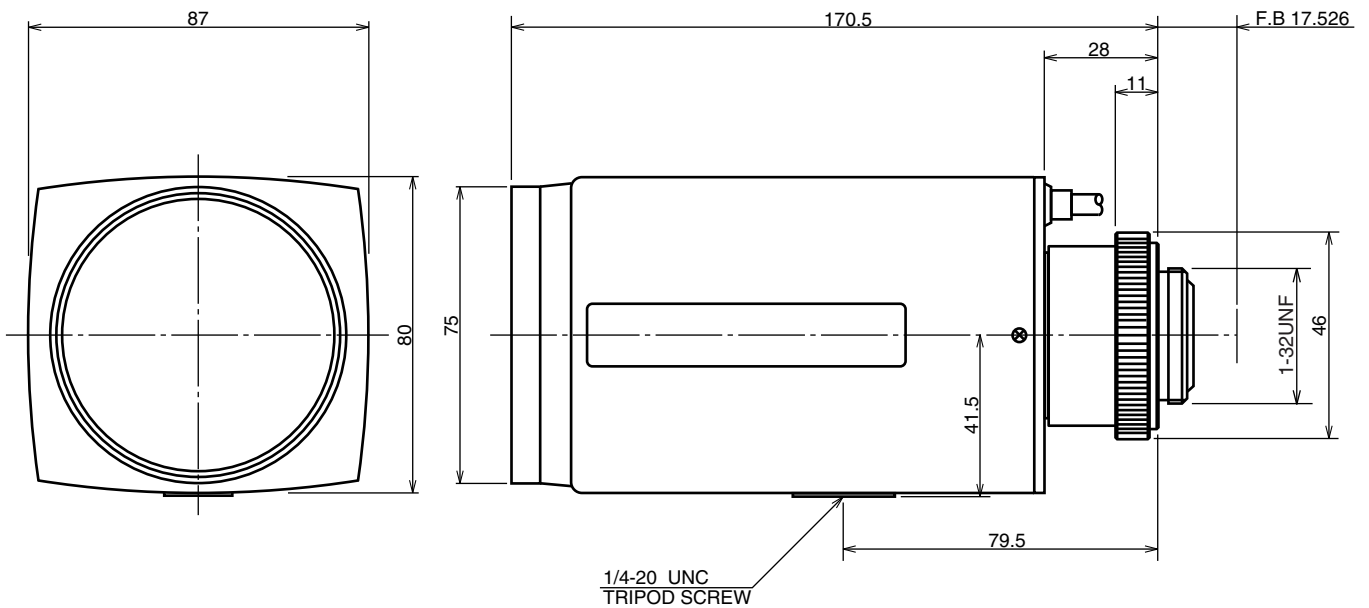

Unit:mm

【CIRCUIT DIAGRAM】

