

JZ1169RAI

Image Size: $\frac{2}{3}$ $\frac{1}{2}$ $\frac{1}{3}$ $\frac{1}{4}$

[SPECIFICATIONS]

Focal Length :	11.5 - 69mm	Photometry Range :	Approx. 40% - 70% Variable to Vp-p
Maximum Relative Aperture :	1:1.4	Input Impedance :	High Impedance
Iris :	F1.4 - Approx. 1200 (With ND Spot Filter)	Operation : Zoom :	Motorized(DC+/-6.4V, Max40mA) Speed Approx. 6sec.
Zoom Ratio :	6X	Focus :	Motorized(DC+/-6.4V, Max40mA) Speed Approx. 7sec.
Sensitivity Adjustment :	0.5 - 1.0Vp-p(Image Signal)	Iris :	EE (DC+8.5 to 16V : Fixed Voltage, Max60mA) Speed Within 3sec.
Angular Field of View :	41.9 X32.0 deg. at 11.5mm 7.3 X 5.5 deg. at 69mm	EE Mechanism :	The built-in EE Amp amplifies the difference between the video signal from the camera and the preset Iris signal level. It causes the Iris to change size.
Image Format :	8.8X6.6mm(D11mm)	EE Accuracy :	With Input Video Signal 0.7Vp-p Within+/-15% of Mean Value
Minimum Object Distance :	1.0m(From Front Vertex)	Operation Temperature :	-10 to +50
Object Dimensions at M.O.D. :	72.8X54.6cm at 11.5mm 12.8X 9.6cm at 69mm	Mount :	C-Mount(Adjustable Lens Position)
Optical Back Focal Distance :	17.93mm(In Air)	Front Thread :	52mm P0.75
Flange Back :	17.526mm	Size, Weight :	70X60X102.5mm, Approx. 500g
Input Signal :	Composite Video Signal or Video Signal		

[COMPOSITION]

Lens1
Lens Cap1
Dust Cap1

[DIMENSIONS]

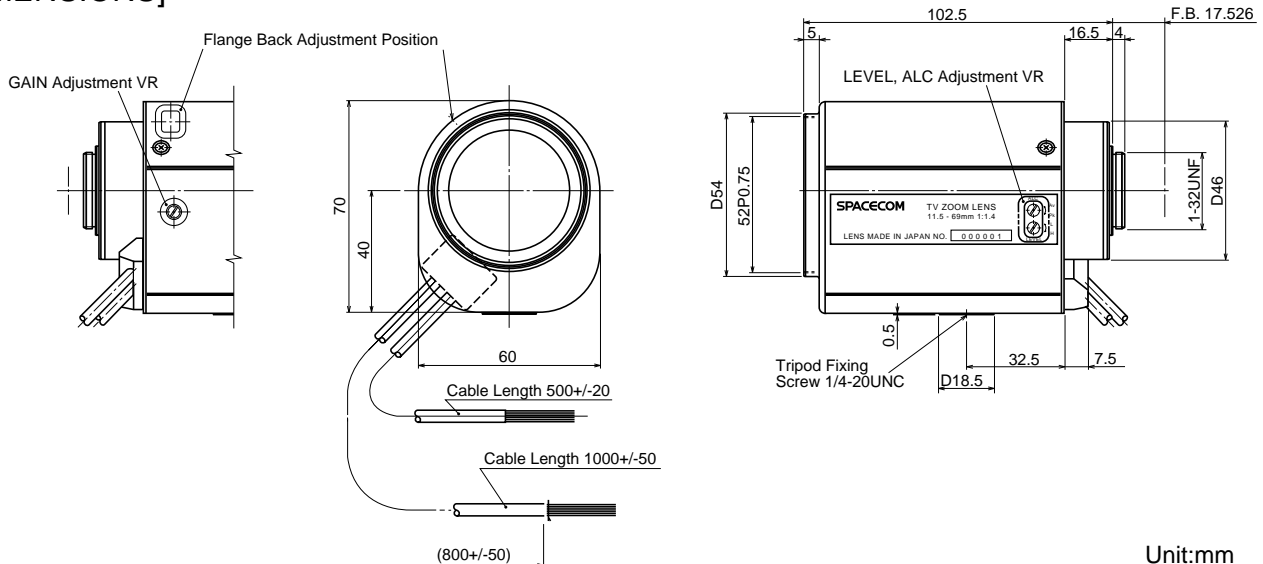

[CIRCUIT DIAGRAM]

